

## Shimge Pump Industry (Jiangsu) Co., Ltd.

# Technical Specification



Product name: APF series Intelligent Variable Frequency Circulating Pump

Product model: APF25-8-130E FPWM1

Version: A0.1

Date: 12/08/2023

Applicable customers: Shimge Standards

Version	Modifying mark	Modified content	Modifying date	Modified by

Confirmed and signed by the producer

Confirmed by:	Reviewed by:	Approved by:
---------------	--------------	--------------

**Contents**

1 Product Overview ..... 3

    1.1 Model description ..... 3

    1.2 Product application ..... 3

    1.3 Main features ..... 4

    1.4 Operating conditions ..... 4

    1.5 Pumped medium ..... 4

    1.6 Pump Installation Requirements ..... 5

    1.7 Technical Parameters ..... 5

2 Product Functions ..... 6

    2.1 Hydraulic Performance Curve ..... 6

    2.2 PWM ..... 7

    2.3 Start-up surge current ..... 11

    2.4 Operation and Panel Display ..... 12

3 Quality and Safety Requirements ..... 14

    3.1 Executive standards ..... 14

    3.2 Pump Identification ..... 14

4 Pump Structure ..... 14

5 Wiring Diagram ..... 16

6 Product Packaging ..... 17

7 Instructions for Use ..... 18

**Appendix A: Dimensional drawing of water pump**

**Appendix B: Nameplate**

**Appendix C: Certificates**

## 1 Product Overview

APF series intelligent variable frequency circulating pump (hereinafter referred to as the electric pump) is subject to the Q/SG 602 standard. The stator of the motor is completely shielded, and the rotating parts are immersed in clean water, which plays a role of cooling and lubrication during operation. The can of the electric pump adopts a thin-walled structure, which completely shields and isolates the inner iron core of the motor from the water, and replaces the traditional mechanical seal structure, solving the seal leakage problem of conventional water pumps. The rotating parts adopt ceramic bearings and ceramic shafts, which are wear-resistant and lubricated with clean water, which can cool the motor and reduce noise. The electric pump is not overloaded when working at the full lift, and as long as it is used correctly, it is generally free of maintenance.

### 1.1 Model description

APF25-8-130E FPWM1	
APF	Intelligent Variable Frequency Circulating Pump
25	The nominal diameter of suction inlet and discharge outlet is 25mm
8	Maximum lift: 8 m (Lift at the flow of 0 m <sup>3</sup> /h)
130	The length of the pump body from inlet to outlet is 130mm
E	Anti-condensation
F	The feedback signal is flow observation
PWM1	The logic of the external speed control signal is: FPWM1

### 1.2 Product application

This series of products are designed for heating or cooling systems and can be used in domestic hot water circulation systems, heating, ventilation and air conditioning (HVAC) systems and other systems, such as:

- Floor heating water mixing system
- Air energy hot water circulating system
- HVAC
- Boiler system
- Heat pump

APF Series Intelligent Variable Frequency Circulating Pump

- Micro combined heat and power (CHP)

**1.3 Main features**

- Energy Efficiency Index  $EEI \leq 0.21$ -Part3
- Permanent magnet motor, intelligent frequency conversion control
- The controller and the motor are designed as a whole, and the whole pump has a compact structure and a small installation size
- Optional quick-plug structure for cables, convenient for installation and maintenance
- External PWM speed control
- Low noise, no leakage

**1.4 Operating conditions**

- Medium temperature:  $-20^{\circ}\text{C} \sim 95^{\circ}\text{C}$
- Ambient temperature:  $-20^{\circ}\text{C} \sim 50^{\circ}\text{C}$

Medium and ambient temperature comparison table

Maximum ambient temperature (°C)	Maximum liquid temperature (°C)
30	95
55	70

- Maximum system pressure: 1.0MPa (10bar)
- Protection class: IP44
- Rated voltage/frequency: 230V (-10%~6%), 50/60Hz
- Noise: No greater than 45dB
- Installation method: The water inlet and outlet of the pump body are connected by unions, and the electric pump is installed along the horizontal direction of the motor shaft;
- To avoid cavitation noise and damage to the pump bearing, the following pressure should be maintained at the pump inlet.

Liquid temperature (°C)	85	95
Inlet pressure	$\geq 0.5\text{m head}$	$\geq 2.8 \text{ m head}$
	$\geq 0.05\text{bar}$	$\geq 0.27\text{bar}$

**1.5 Pumped medium**

- Heating or cooling water: Clean, free of solids and mineral oils, non-toxic, chemically neutral,

## APF Series Intelligent Variable Frequency Circulating Pump

close to the properties of water;

- Ethylene glycol solution with solubility  $\leq 50\%$
- The pH value of medium is 6.5~8.5
- The volume content of solid particles does not exceed 0.1 per unit volume, and the particle size does not exceed 0.2 mm
- The number of filter meshes shall not be less than 55

### 1.6 Pump Installation Requirements

- When the pump is installed, the motor shaft must be parallel to the horizontal plane
- Do not run the pump without water
- Before installing the pump, it shall be ensured that the piping system is in good condition and clean, as impurities such as welding slag and dirt may damage the pump
- The water pump shall be installed in a place convenient for maintenance and replacement

### 1.7 Technical Parameters

Parameters	Specification description
Electric pump form	Centrifugal circulating pump (non-self-priming)
Power source	AC 230V
Frequency	50/60Hz
Input power	8-90W
Current	0.1-1.0A
Range of speed	1750~4500r/m
IP protection class	IP44
Insulation grade	Class F
EEI	$\leq 0.21$ -Part3
Noise	$\leq 45$ dB
Maximum lift	8 m
Maximum flow rate	4.3m <sup>3</sup> /h
Matching pipe diameter (thread)	DN25 (G1.5)
Rotating direction of the rotor	Clockwise from the control box to the pump body

## 2 Product Functions

No.	Items	Function description
1	Operation and control mode	Internal operation at the maximum constant power + PWM external speed control
2	Start	Maximum torque start
3	PWM external speed control	PWM signal automatically recognizes entering and exiting speed regulation mode
4	Display	LED light, display of speed control mode, display of fault code
5	Protection function	Overcurrent protection, over/undervoltage protection, phase loss protection, locked rotor protection, over-temperature protection
6	PWM feedback	Current electric pump flow feedback, fault feedback

### 2.1 Hydraulic Performance Curve

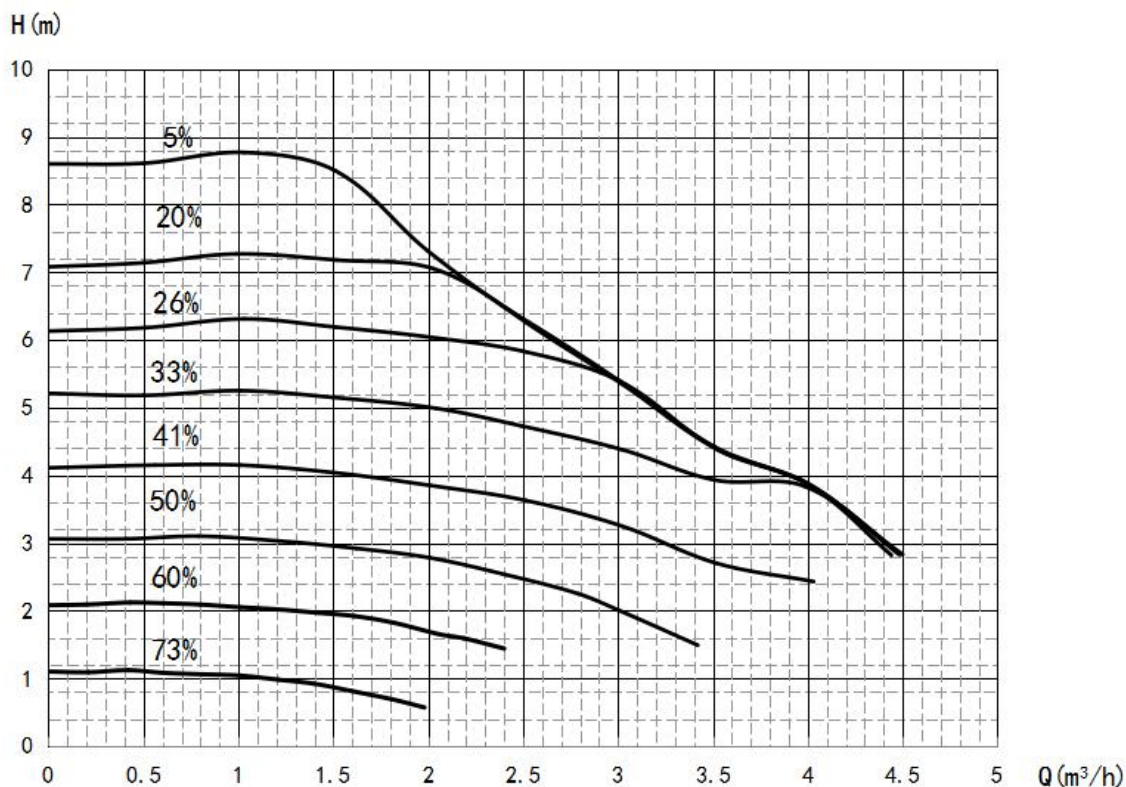

APF Series Intelligent Variable Frequency Circulating Pump

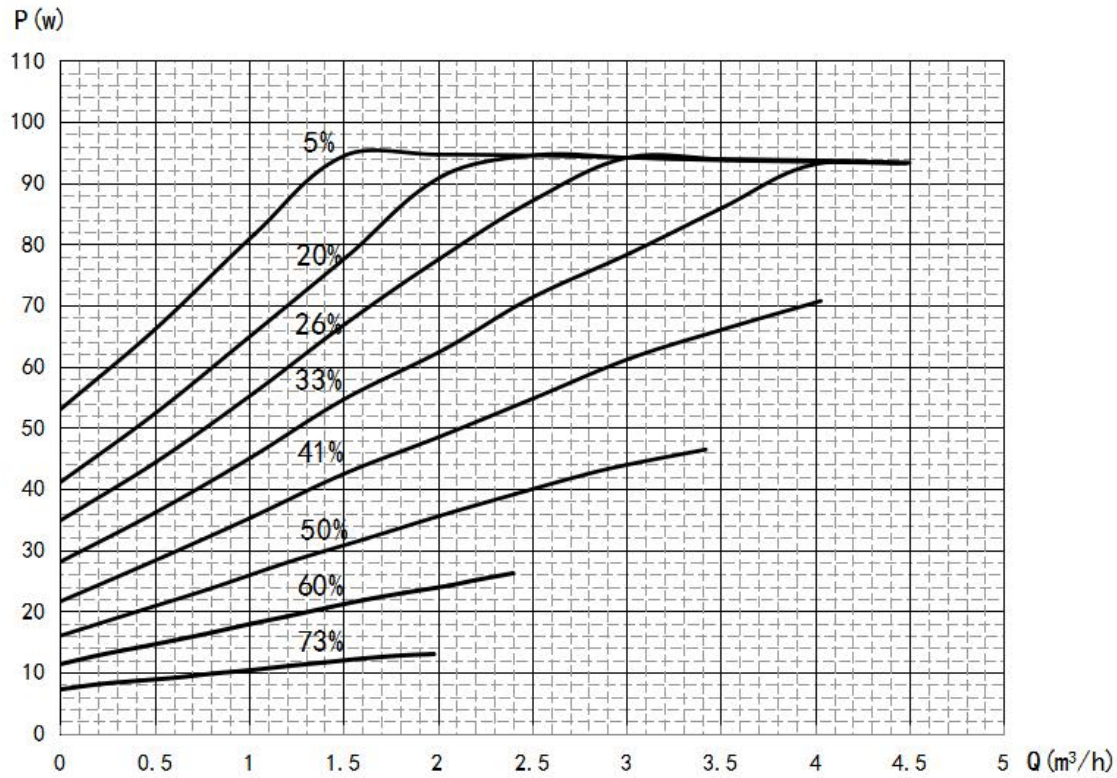

Model	Pipe diameter	Maximum lift	Rated flow rate	Rated lift	Maximum flow rate	Maximum input power	Pump efficiency
	(mm)	(m)	(m³/h)	(m)	(m³/h)	(W)	(%)
APF25-8-130E FPWM1	DN25	8	3	5	4.3 (2.5m)	90	47

2.2 PWM

2.2.1 Basic control logic

When the PWM signal is connected, the pump operation is controlled by the PWM signal, and when there is no PWM signal, the pump operation is controlled by the internal control logic.

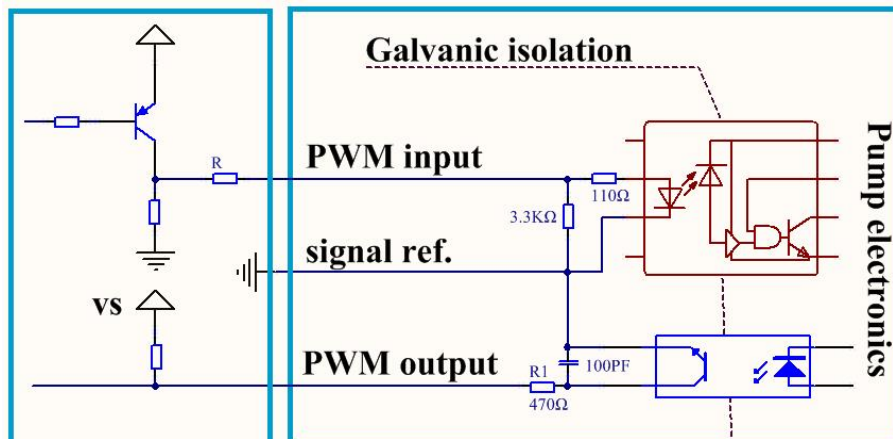

APF Series Intelligent Variable Frequency Circulating Pump

**2.2.2 PWM input signal (PWM1 heating)**

When the PWM signal percentage (duty ratio) is high, if the input signal is fluctuating around the conversion point, the hysteresis may prevent the start and stop of circulating pump. When the PWM signal percentage is low, for safety reasons, the rotating speed of circulating pump is high. If the electric cable in the gas boiler system is damaged, the pump will continue running at the maximum speed to transmit heat from the primary heat exchanger. This is also applicable to heating circulating pump, so as to ensure that the pump can transmit heat in case the cable is damaged.

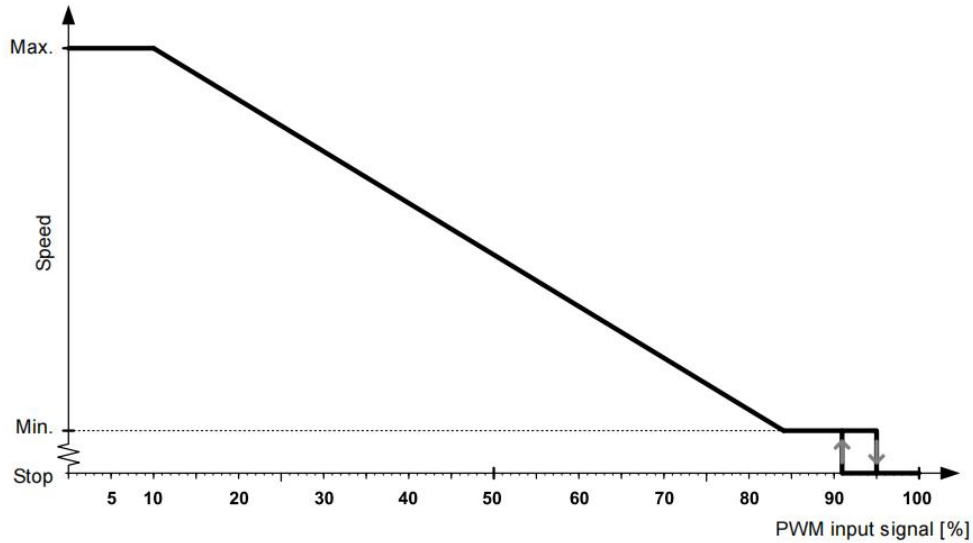

PWM Input signal (%)

PWM Input signal (%)	State of electric pump
0	The electric pump is switched to the non-PWM mode (internal control) for operation, and no PWM signal is input to the system by default.
0<PWM≤10	The electric pump is running at the maximum speed.
10<PWM≤84	The speed of electric pump falls from the maximum speed to the minimum speed in a linear manner.
84<PWM≤91	The electric pump is running at the minimum speed.
91<PWM≤95	If the input signal is fluctuating around the speed change point, it may prevent the start and stop of pump according to the principle of hysteresis.
95<PWM≤100	Standby, the water pump stops running

**2.2.3 Definition of PWM signal property**

Definitions of input signal properties	Optically coupled isolation	YES
	PWM input frequency	100-5000Hz (2000Hz is conventionally used)
	High level input voltage $U_{IH}$	4-24V
	Low level input voltage $U_{IL}$	<1V
	High level input current $I_H$	3mA-30mA

APF Series Intelligent Variable Frequency Circulating Pump

	Adjustable range of PWM	0-100%
	Length of signal line	<3m
	Rising edge or falling edge time	<T/1000
Definitions of feedback signal properties	Optically coupled isolation	YES
	PWM feedback signal frequency	75 (±3) Hz
	PWM output signal accuracy	± 0.2 m <sup>3</sup> /h
	Maximum pull-up voltage at output pole VS	3V-24V
	Current drive capability at output pole Iout	1mA-2.5mA
	PWM feedback range	0-100%
	Length of signal line	<3m
	Rising edge or falling edge time	<T/500
	PWM output pull-up resistance R2	(VS-0.2)/Iout-R1

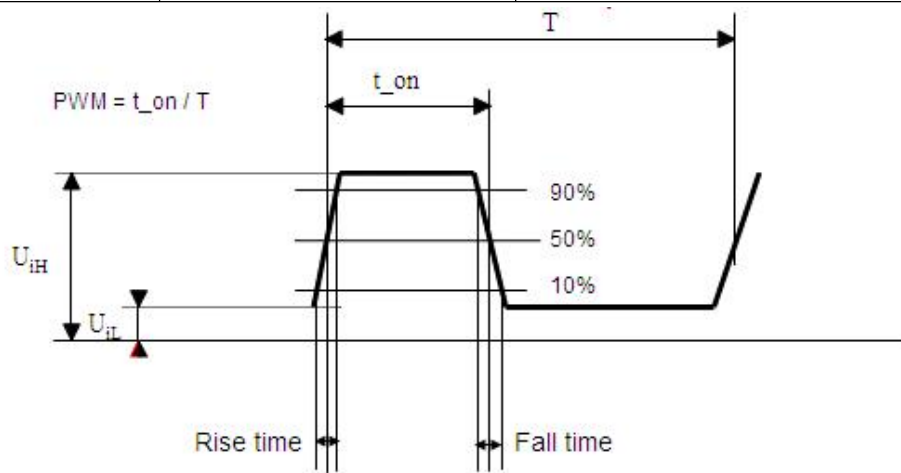

PWM waveform

APF Series Intelligent Variable Frequency Circulating Pump

2.2.4 PWM output

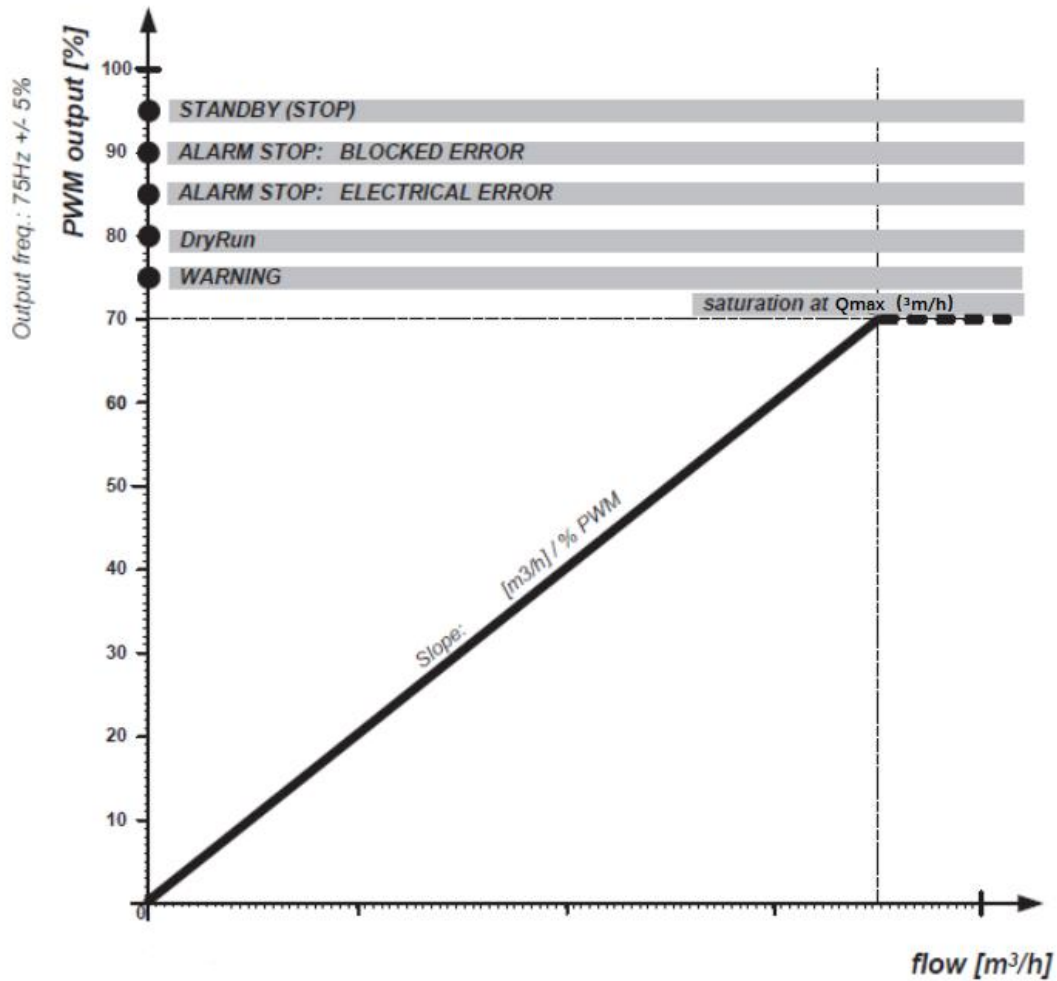

Feedback logic diagram

PWM output signal (%)	Pump information	Causes	Priority
0-70	The pump is running normally, feeding back the flow information	/	5
80	Alarm/cycle start! Overcurrent (short circuit), IPM overtemperature fault; the electric pump resumes running after the fault is eliminated.	The electric pump is short-circuited or overheated; the IPM module is over-temperature.	4
85	Alarm/cycle start! (undervoltage fault <160, overvoltage fault >270); the electric pump resumes running after the fault is eliminated.	The input supply voltage is lower or higher than the operating voltage (160V-270V) of the electric pump	2

## APF Series Intelligent Variable Frequency Circulating Pump

90	Alarm/cycle start! Electric error (phase loss fault); jamming error (locked-rotor fault); pump dry running fault; the electric pump resumes running after the fault is eliminated.	UVW phase loss or UVW short circuit of the motor causes hardware overcurrent; the rotor is stuck and the pump is jammed; the pump runs without water.	3
95	The pump is in standby	/	1

Feedback code description:

- When the input voltage is lower than 185VAC, the minimum output of feedback signal is 0.8m<sup>3</sup>/h (14%).
- When PWM inputs the standby signal (the pump is in the stopped state when the signal is 95%-100%), the pump receives the standby signal and clear all faults and the number of fault restarts.

Feedback flow description:

Model	Feedback slope i value	Max. feedback flow rate (m <sup>3</sup> /h)	Flow calculation formula (Q: m <sup>3</sup> /h, PWMout: %)
8m	0.05	3.5	Q=0.05*PWMout

Notes for under/overvoltage protection:

- The accuracy range of under/overvoltage protection voltage value is  $\pm 5V$
- Undervoltage reset: When the voltage is lower than 160V, the electric pump stops running under the action of undervoltage protection, and the voltage needs to be reset to 165 V to start the electric pump normally (when the voltage changes dynamically)

Overvoltage reset: When the voltage is higher than 270V, the electric pump stops running under the action of overvoltage protection, and the voltage needs to be reset to 265 V to start the electric pump normally (when the voltage changes dynamically)

### 2.3 Start-up surge current

Pump model	Voltage	I <sub>max</sub>	T <sub>max</sub>
APF_FPWM1	180 V	<6 A	<25ms
	230 V	<6 A	<25ms
	265 V	<6A	<25ms

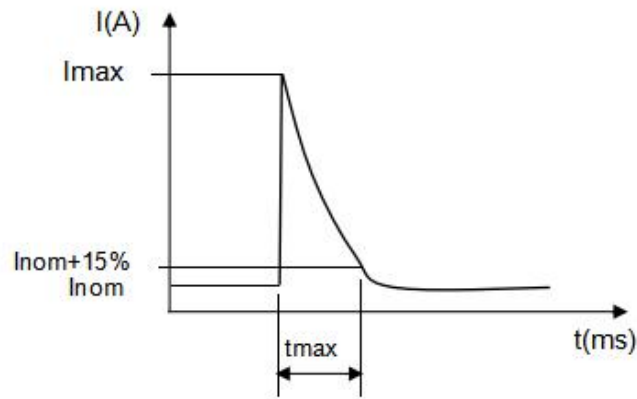

Peak current graph

## 2.4 Operation and Panel Display

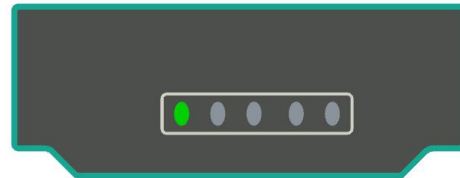

### 2.4.1 Overview of operation and panel

When the pump has no PWM signal input, the pump runs according to the maximum constant power curve; when there is a PWM signal input, it runs according to the PWM speed control logic; the right picture is an overview of the panel.







### 2.4.2 Mode display

After the power is turned on, all green LED lights flash 3times, and the speed control mode is displayed as follows:

Pump status	Display light status	Pump status	Display light status
No PWM signal		PWM signal speed control	

## APF Series Intelligent Variable Frequency Circulating Pump

### 2.4.3 Fault display

Function name	Description	Code
Dry running protection	When the pump runs without water, the pump stops for 5 seconds after 1 minute of operation judgment, the electric pump reports the feedback code 90% and the panel displays the fault code, and the pump stops/runs according to the control signal at the same time for unlimited times. When the fault disappears, the pump resumes running.	
Locked-rotor protection	When the rotor shaft of the electric pump is stuck, the pump stops for 5 seconds, the electric pump reports the feedback code 90% and the panel displays the fault code, and the pump stops/runs according to the control signal at the same time for unlimited times. When the fault disappears, the pump resumes running.	
Phase loss protection	When a phase loss fault occurs to the electric pump, the pump stops for 5 seconds, the electric pump reports the feedback code 90% and the panel displays the fault code, and the pump stops/runs according to the control signal at the same time for unlimited times. When the fault disappears, the pump resumes running.	
Overvoltage protection	In abnormal conditions, when the input voltage is higher than 270V, the electric pump will enter the protection state; the electric pump reports the feedback code 85% and the panel displays the fault code. When the voltage returns to 265V, the pump will run or stop according to the control signal.	
Undervoltage protection	In abnormal conditions, when the input voltage is lower than 160V, the electric pump will enter the protection state; the electric pump reports the feedback code 85% and the panel displays the fault code. When the voltage returns to 165V, the pump will run or stop according to the control signal.	
Overcurrent (short circuit) protection	When a short circuit or overheating fault occurs to the electric pump, the electric pump reports the feedback code 80% and the panel displays the fault code. When the fault disappears, the pump resumes running.	
Over-temperature protection	When a short circuit or overheating fault occurs to the electric pump, the electric pump reports the feedback code 80% and the panel displays the fault code. When the fault disappears, the pump resumes running.	

Notes for protection functions: The faults above can be cleared by inputting the standby signal.

### 3 Quality and Safety Requirements

#### 3.1 Executive standards

3.1.1 Q/SG 602 Intelligent Variable Frequency Circulating Pump

3.1.2 GB 4706.1 Household and similar electrical appliances - Safety - Part 1: General requirements

3.1.3 GB 4706.71 Household and similar electrical appliances - Safety - Particular requirements for stationary circulation pumps for heating and service water installations

#### 3.2 Pump Identification

Functional requirements	Description
Product brand	SHIMGE
Protection class	IP44
Temperature resistance class	Class F
CE certification	CE
Erp certification	EEI ≤0.21-Part3

### 4 Pump Structure

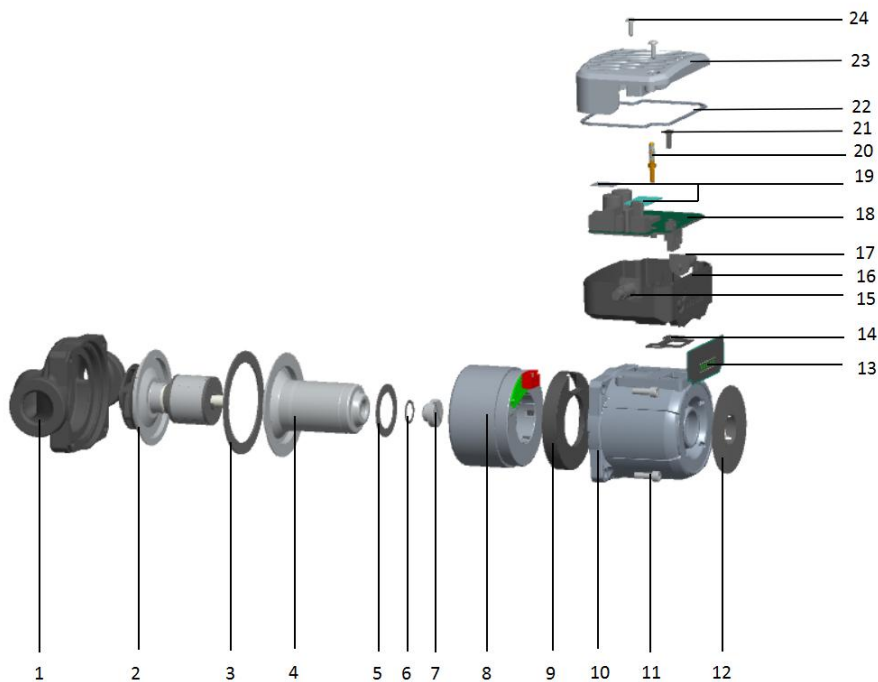

APF Series Intelligent Variable Frequency Circulating Pump

No.	Name	Component	Material
1	Pump body	/	HT200
2	Rotor parts	Magnetic steel	Ferrite
		Magnetic steel sleeve	304
		Shaft/bearing	Alumina ceramics
		Pump cover	304
		Thrust assembly	Carbon graphite & EPDM
		Impeller	PA66H59
3	Flat sealing washer I	/	EPDM
4	Can assembly	Can body	304
		Bearing	Alumina ceramics
5	Flat sealing washer II	/	EPDM
6	O-ring	/	EPDM
7	Vent cock	/	H59
8	Can assembly	Can body	304
		Bearing	Alumina ceramics
8	Stator coil	/	Assembly
9	Anti-breakdown jacket	/	PA6
10	Casing	/	YL102
11	Hexagon socket head cap screw	/	201
12	Nameplate	/	PA66G30
13	Display film	/	PVC+PET
14	Seal gasket	/	EPDM
15	Cable	/	H05VV-F3
16	Lower cover of control box	/	PC
17	Signal line	/	Assembly
18	Control panel (component)	/	Assembly
19	Thermally conductive silicone pad	/	Silicone rubber
20	Rubber joint	/	Assembly
17	Control panel (component)	/	Assembly
18	Rubber joint	/	Assembly
19	Cross recessed small pan head screw	/	304
20	Cover plate	/	PA6

APF Series Intelligent Variable Frequency Circulating Pump

21	Cross recessed small pan head screw	/	304
22	Seal ring of control box	/	Silicone
23	Lower cover of control box	/	YL102
24	Cross recessed pan head self-tapping screw	/	304

## 5 Wiring Diagram

### 5.1 Signal line (Customizable)

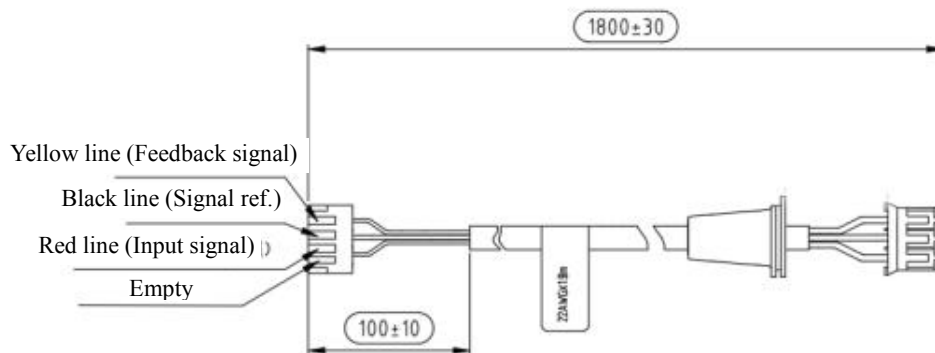

The black line of the PWM signal line is connected to the GND mark (ground) of the control board, the red line is connected to the Input mark (input), and the yellow line is connected to the Output mark (output).

End terminal: VHR-4N (white)

### 5.2 Power cord (Customizable)

APF Series Intelligent Variable Frequency Circulating Pump

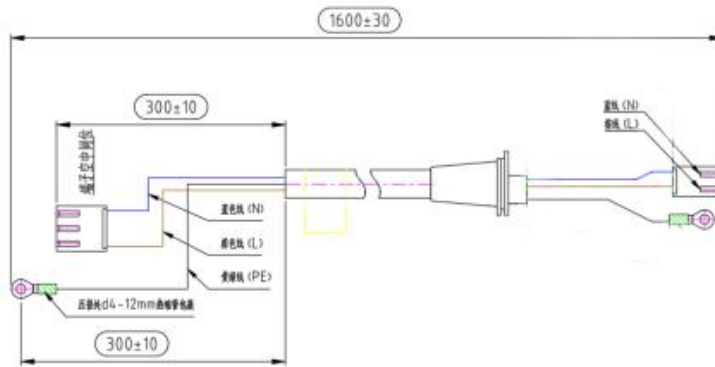

The brown wire of the power line is connected to the L mark (live wire) of the control board, the blue wire is connected to the N mark (neutral wire), and the yellow-green wire is connected to the PE mark (grounding).

End terminal: VHR-3N (yellow) + ground wire OT1-4 ring terminal.

## 6 Product Packaging

- Inner/outer box packaging



(For reference only, subject to actual packaging)

- Pallet packaging

Scheme: 4 layers in total, 6 boxes per layer, 8 units per box, a total of 192 units per pallet.

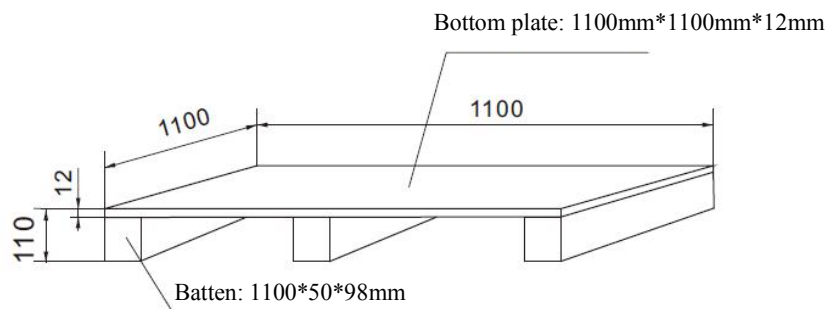

(For reference only, subject to actual packaging)

## 7 Instructions for Use

7.1 Before installing the electric pump, check whether the piping system is connected reliably, and ensure that impurities, welding slag, dirt, etc. in the pipeline have been removed;

7.2 The electric pump shall be installed in a dry and ventilated place to avoid short-circuit due to damp or water splashing, and the installation shall be convenient for future maintenance and replacement;

7.3 When the electric pump is installed in the open air, a protective cover shall be added, and when it is installed indoors, it shall be prevented from being splashed by water to avoid electric shock; do not install it in the bathroom to prevent water vapor or water from entering the junction box and causing electric leakage;

7.4 In order to facilitate the maintenance of the electric pump in the future, it is recommended to install an independent shut-off valve at the water inlet and outlet of the electric pump;

7.5 When the electric pump supplies water for the supporting heating system, do not touch the electric pump and its pipes with your hands to avoid scalding;

7.6 The power plug shall be grounded strictly, and the grounding pin of the plug shall be reliably connected to the grounding hole of the power socket, and the power grounding plug must not be changed without authorization;

7.7 When the electric pump is working, if you want to adjust the position of the electric pump or touch the electric pump, you must cut off the power first to prevent accidents;

7.8 In winter, when the ambient temperature is lower than 0°C, if the electric pump stops running, the water in the piping system shall be drained to avoid the cracking of the pump body;

## Appendix A: Dimensional drawing of water pump

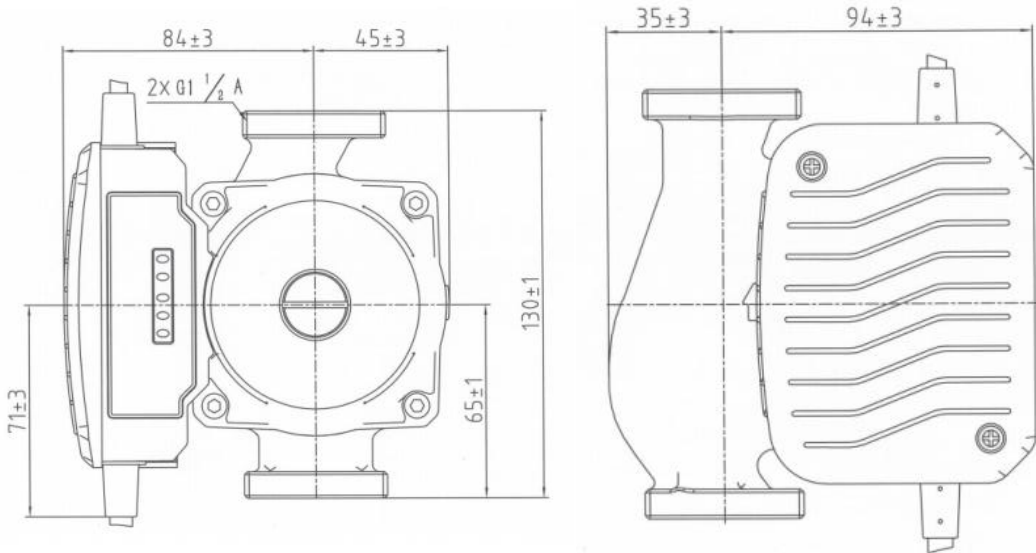

### Accessories (Flexible sealing gasket)

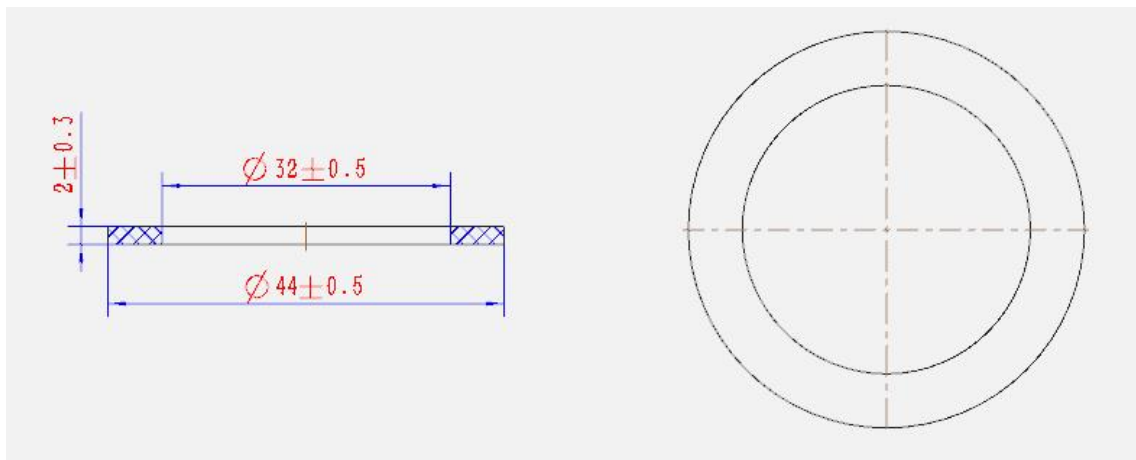

## Appendix B: Nameplate



Production serial number,  
 varying with the date

# Appendix C: Certificates

## CE Certificate



### Attestation of Conformity No. E8A 101057 0107 Rev. 00

**Holder of Certificate:** SHIMGE PUMP(JIANGSU)CO.,LTD  
The north side of Cai Road,  
The west side of Ruisheng Avenue,  
Economic Development Zone  
223600 Shuyang, Jiangsu Province  
PEOPLE'S REPUBLIC OF CHINA

**Name of Object:** Circulation pump  
High Efficiency Circulation Pump

This Attestation of Conformity is issued on a voluntary basis according to the Directive 2014/30/EU relating to electromagnetic compatibility. It confirms that the listed apparatus complies with all essential requirements of the directive and is based on the technical specifications applicable at the time of issuance. It refers only to the particular sample submitted for testing and certification. For details see: [www.tuvsud.com/ps-cert](http://www.tuvsud.com/ps-cert)

**Test report no.:** 878882218624-00

**Date,** 2022-10-13

*Jun Bao*  
( Jun Bao )

TUV<sup>®</sup>

Page 1 of 4  
After preparation of the necessary technical documentation as well as the EU Declaration of conformity the required CE marking can be affixed on the product. That Declaration of conformity is issued under the sole responsibility of the manufacturer. Other relevant EU-directives have to be observed.

TUV SUD Product Service GmbH • Certification Body • Rollerstraße 65 • 80339 Munich • Germany

ZERTIFIKAT ◆ CERTIFICATE ◆ 證書 ◆ CERTIFICADO ◆ CERTIFIKAT ◆ 證書 ◆ CERTIFICATE ◆ CERTIFICADO ◆ CERTIFIKAT



### Attestation of Conformity No. E8A 101057 0107 Rev. 00

**Modell(s):** APF20-4-130, APF25-4-130, APF25-4-180, APF32-4-180, APF32-4-180A, APF25-4-130A, APF25-4-180A, APF32-4-180A, APF20-6-130, APF25-6-130, APF25-6-180, APF32-6-180, APF20-6-130A, APF25-6-130A, APF25-6-180A, APF32-6-180A, APF25-8-180, APF32-8-180, APF25-8-130A, APF25-8-180A, APF32-8-180A, APF20-8-130E FPWM1, APF25-8-130E FPWM1, APF25-8-180E FPWM1, APF32-10-180, APF25-10-180 PWM1, APF32-10-180 PWM1, APF25-10-180 PWM2, APF32-10-180 PWM2, APF25-10-180E FPWM1, APF32-10-180E FPWM1, APF25-10-130E FPWM1, APF32-12-180, APF25-12-180 PWM1, APF25-12-180 PWM2, APF32-12-180 PWM1, APF25-12-180 PWM2, APF32-12-180E, APF20-12-130E FPWM1, APF25-12-130E FPWM1, APF25-12-180E FPWM1, APF32-12-180E FPWM1

**Description of Object:**  
Rated Voltage: 230V~  
Rated Frequency: 50/60Hz  
Rated Input Power: See model list

Page 2 of 4  
After preparation of the necessary technical documentation as well as the EU Declaration of conformity the required CE marking can be affixed on the product. That Declaration of conformity is issued under the sole responsibility of the manufacturer. Other relevant EU-directives have to be observed.

TUV SUD Product Service GmbH • Certification Body • Rollerstraße 65 • 80339 Munich • Germany

TUV<sup>®</sup>

ZERTIFIKAT ◆ CERTIFICATE ◆ 證書 ◆ CERTIFICADO ◆ CERTIFIKAT ◆ 證書 ◆ CERTIFICATE ◆ CERTIFICADO ◆ CERTIFIKAT

ZERTIFIKAT ◆ CERTIFICATE ◆ 認證書 ◆ CERTIFICADO ◆ CERTIFICAT



## Attestation of Conformity

No. D6 101057 0108 Rev. 00

**Holder of Attestation:** **SHIMGE PUMP(JIANGSU)CO.,LTD**  
 The north side of Cixi Road,  
 The west side of Ruisheng Avenue,  
 Economic Development Zone  
 223600 Shuyang, Jiangsu Province  
 PEOPLE'S REPUBLIC OF CHINA

**Product:** **Circular Pumps**  
**High Efficiency Circulation pump**

**Model(s):** **APF25-10-130E FPWM1, APF25-10-130E FPWM2,  
 APF25-10-180E FPWM1, APF25-10-180E FPWM2**

**Parameters:**

Rated voltage:	230V~
Rated frequency:	50/60Hz
Rated input power:	140W Max.
Protection class:	I
Degree of protection:	IP 44
Rated Head:	10m Max.
Rated Flow:	5.2 m <sup>3</sup> /h Max.
Declared EEI:	Less than 0.23

Implementation Measure EC Regulation  
 No 641/2009: 2009-07-22 amended by  
 (EU) 622/2012:2012-07-11, (EU) 2016/2282: 2016-11-30,  
 (EU) 2019/1781:2019-10-01  
 Stage 2 (2015-08-01)  
 PPP 11093E:2019  
 EN 16297-1:2012  
 EN 16297-2:2012  
 EN 16297-3:2012

**Tested according to:**

This Attestation of Conformity is issued on a voluntary basis and confirms that the listed product fulfils the generic ecodesign requirements as stated in Annex I in combination with the specific ecodesign requirements defined in the above mentioned Implementation Measure and as stated in Annex II of Council Directive 2009/125/EC for the setting of ecodesign requirements for energy-related products. This attestation refers only to the sample submitted to TÜV SÜD PRODUCT SERVICE GMBH for testing and evaluation and to its technical documentation. For details see: [www.tuvsud.com/ps-cert](http://www.tuvsud.com/ps-cert)

**Test report no.:** 874012218627-00

**Date,** 2022-10-21

( Lucy (Jianying) Lu )

 <b>产品认证证书</b>	
<b>证书编号:</b> CQC20008276609	<b>发证日期:</b> 2023年01月04日 <b>有效期至:</b> 长期有效
<b>委托人名称</b>	新界泵业(江苏)有限公司
<b>及注册地址</b>	沭阳县经济开发区瑞声大道西侧、慈溪路北侧
<b>制造商名称</b>	新界泵业(江苏)有限公司
<b>及注册地址</b>	沭阳县经济开发区瑞声大道西侧、慈溪路北侧
<b>生产企业名称</b>	新界泵业(江苏)有限公司
<b>及生产地址</b>	沭阳县经济开发区瑞声大道1号
<b>产品名称和系列、规格、型号</b>	智能变频循环泵 见附件
<b>产品标准和技术要求</b>	GB 4706.1-2005 ;GB 4706.66-2008
<b>认证模式</b>	产品型式试验+初次工厂检查+获证后监督
上述产品符合 CQC11-432215-2009;CQC12-448100-2009 认证规则的要求, 特发此证。 本证书为变更证书, 证书首次颁发日期: 2020年12月02日 本证书的有效性依据发证机构的定期监督获得保持。	
可通过扫描下方二维码或登录国家认监委网站 ( www.cnca.gov.cn ) 查验证书信息	
	<b>签发:</b> 
	<b>中国质量认证中心</b>
	
<a href="http://www.cqc.com.cn">http://www.cqc.com.cn</a>	中国·北京·南四环西路188号9区 100070 电话: +86 10 83886666

AK Certificate

**CERTIFICATE**  
of Conformity



Registration No.: AK 50574117 0001

Report No.: CN23JLIL 001

**Holder:** Shimge Pump Industry (Jiangsu) Co.,Ltd.  
The north side of Cixi Road,  
The west side of Ruisheng Avenue,  
Economic Development Zone,  
Shuyang,  
223600 Jiangsu  
P.R. China

**Product:** Circulation Pump  
(Circulation pump for air conditioner)

**Identification:** Type Designation: APF25-8-130E FPWM1 APF25-8-130E FPWM2  
See more type designations in attachment 1.1  
Remark: The product can be used in A2L and A3  
refrigerate condition after evaluation.  
Clause 22.116 and 22.117 are considered for the  
product. Refer to test report CN23JLIL 001  
for details.

**Tested acc. to:** IEC 60335-1:2010+A1+A2  
IEC 60335-2-40:2018  
IEC 60335-2-51:2019

The certificate of conformity refers to the above mentioned product. This is to certify that the specimen is in conformity with the assessment requirement mentioned above. This certificate does not imply assessment of the production of the product and does not permit the use of a TÜV Rheinland mark of conformity.

Date 13.02.2023

Certification Body  
  
Liwei Lang

TÜV Rheinland LGA Products GmbH - Tillystraße 2 - 90431 Nürnberg